



PROJECT 2028  
05.10.2021

# SO VEENENDAAL T' GOEIE SPOOR

ARCHITECTONISCH UITWERKING GOEDGEKEURDE MASSA



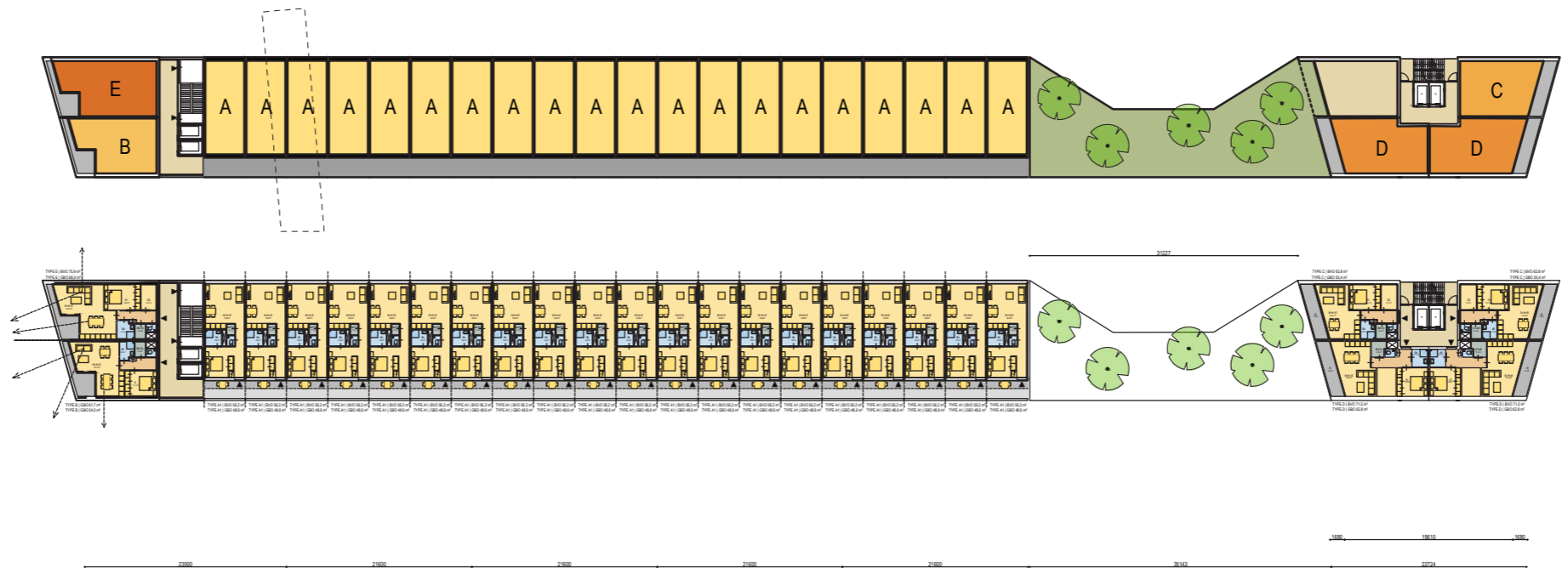
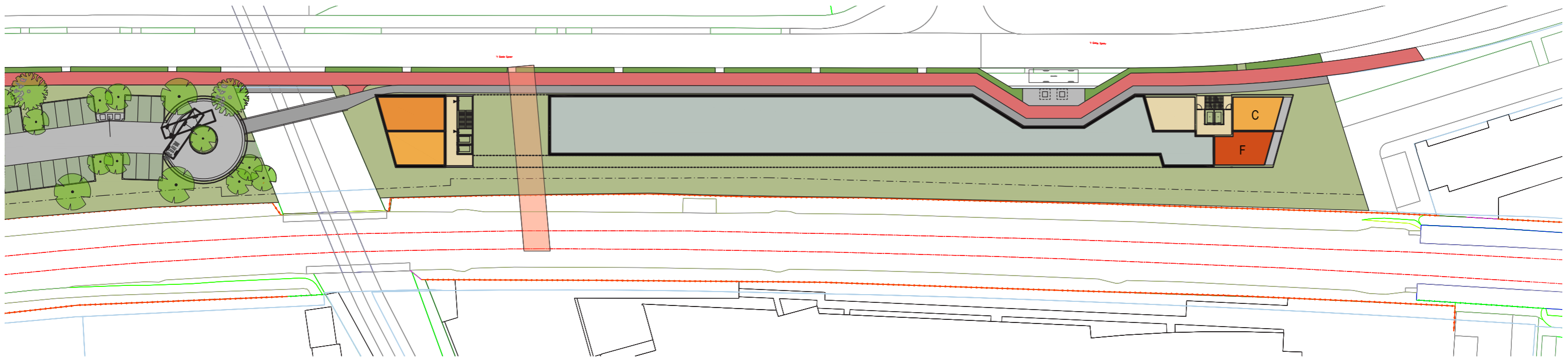

- app type A - GBO 48,6m<sup>2</sup> (46x)
- app type B - GBO 54,0m<sup>2</sup> (8x)
- app type C - GBO 55,4m<sup>2</sup> (18x)
- app type D - GBO 62,8m<sup>2</sup> (19x)
- app type E - GBO 66,0m<sup>2</sup> (7x)
- app type F - GBO ~74m<sup>2</sup> (18x)

Appartementen totaal: 116

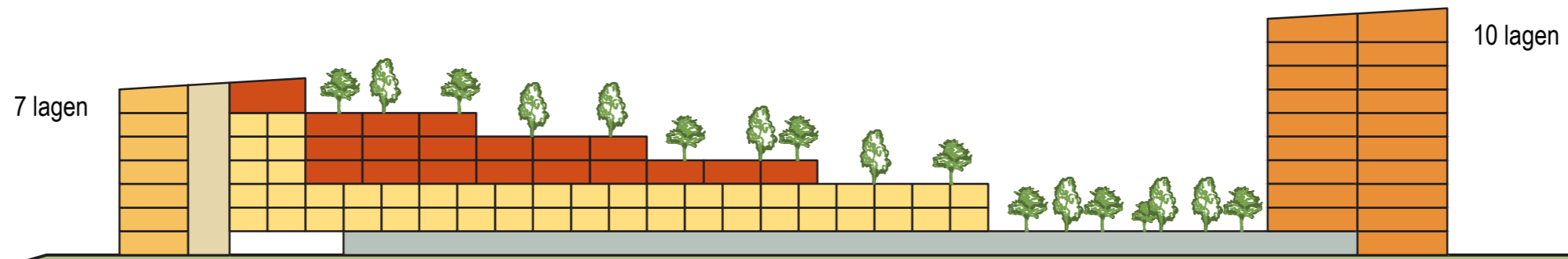

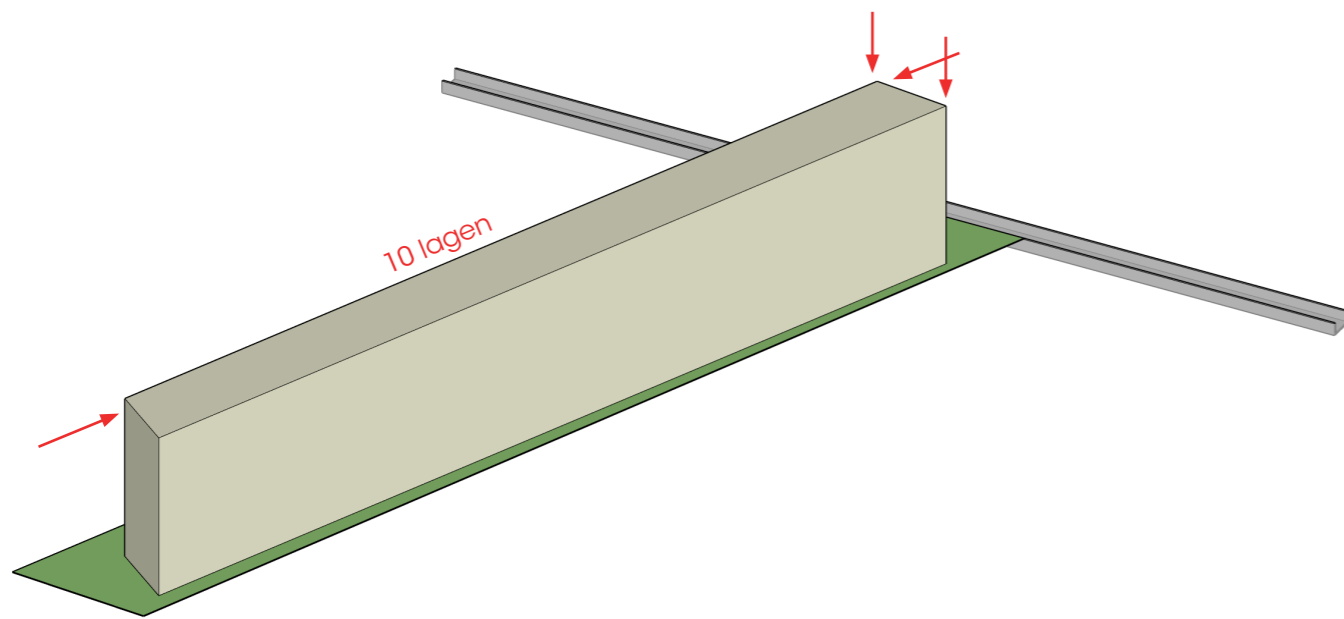

01. Blok 10 lagen manipuleren; koppen richting de zon een zijde verlagen

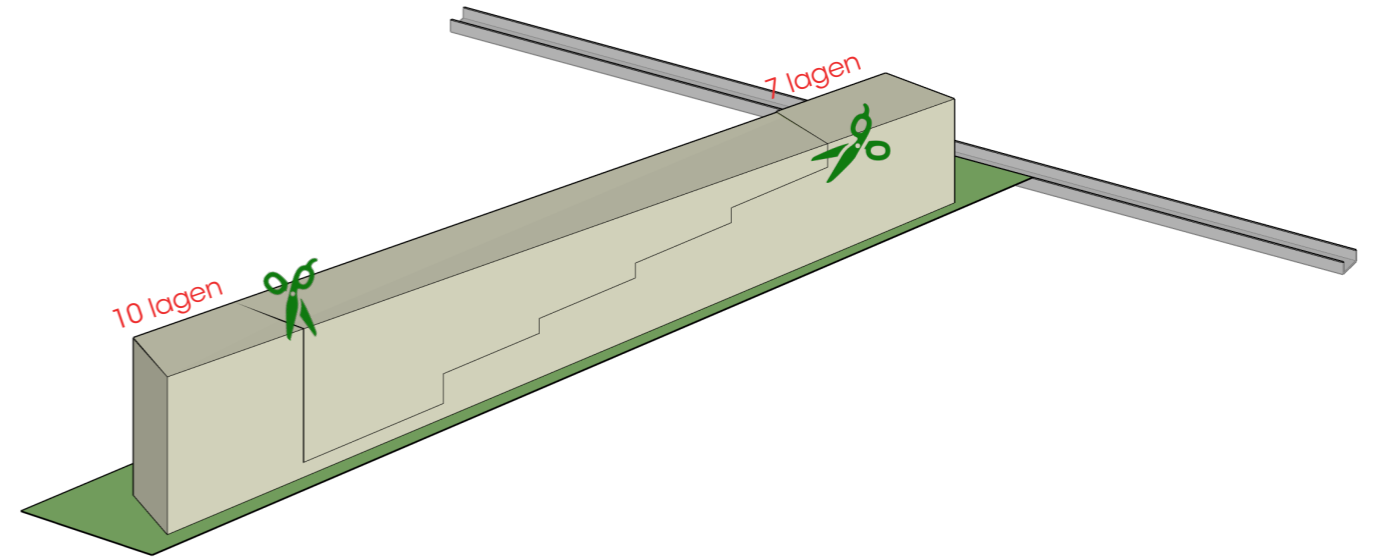

02. Groene getrapte uitsnede vormen terrassen in het volume

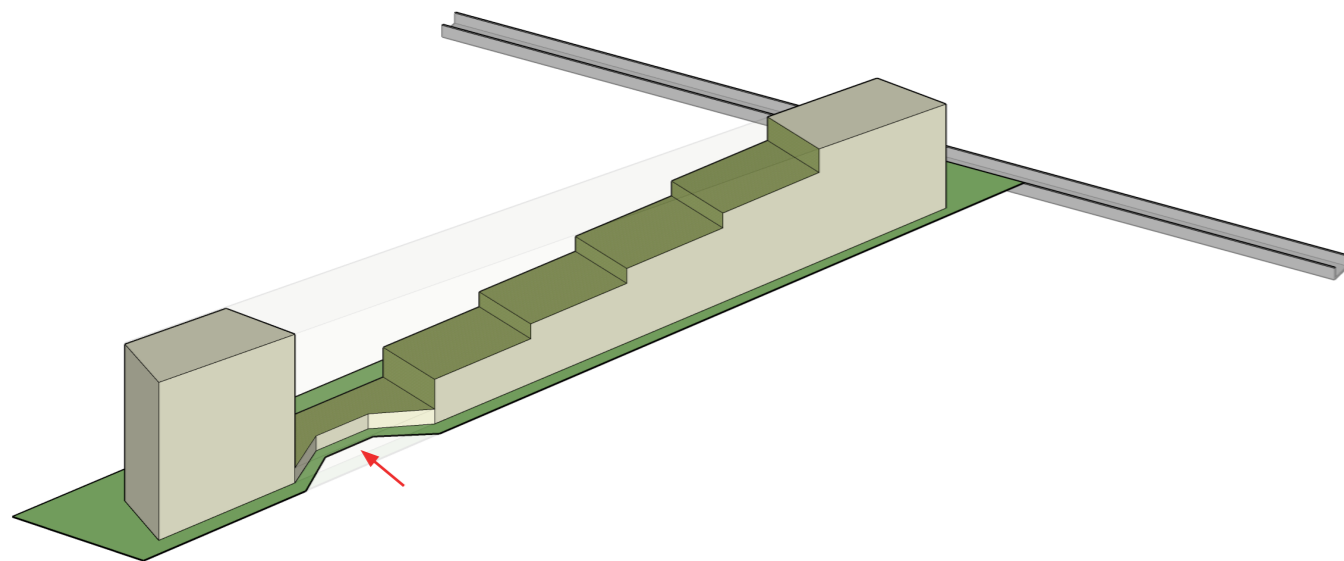

03. Uitsparing voor afvalinzameling maken

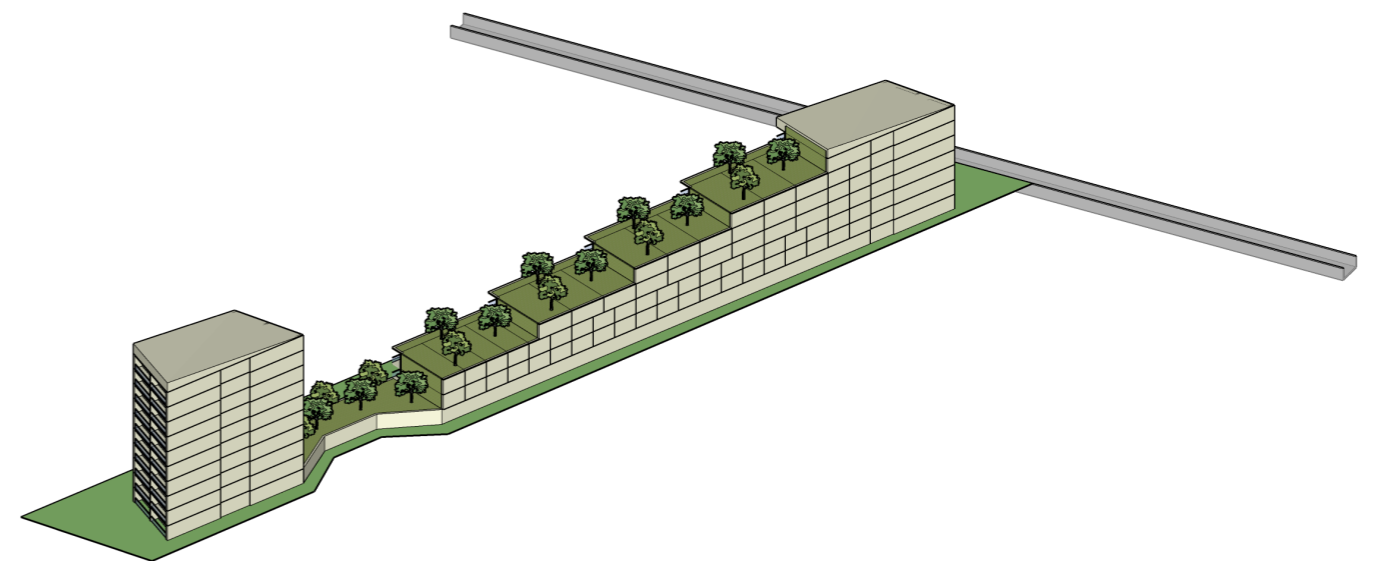

04. Beplanting op groene uitsnedes gedeelde terrassen

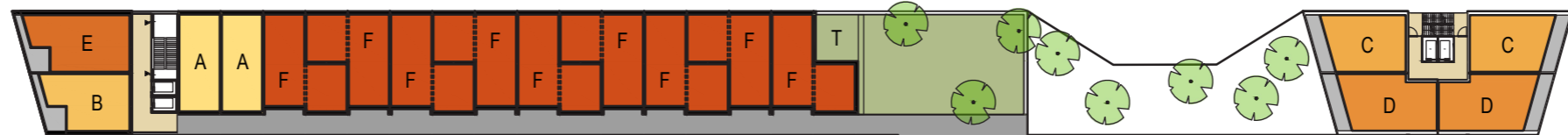
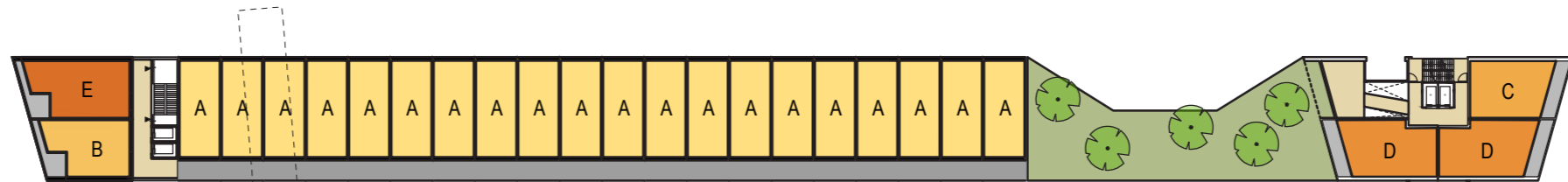

- app type A - GBO 48,6m<sup>2</sup> (41x)
- app type B - GBO 54,0m<sup>2</sup> (7x)
- app type C - GBO 55,4m<sup>2</sup> (18x)
- app type D - GBO 62,8m<sup>2</sup> (19x)
- app type E - GBO 66,0m<sup>2</sup> (7x)
- app type F - GBO ~74m<sup>2</sup> (21x)
- app type G - GBO ~120m<sup>2</sup> (1x)

Appartementen totaal: 114

7 lagen

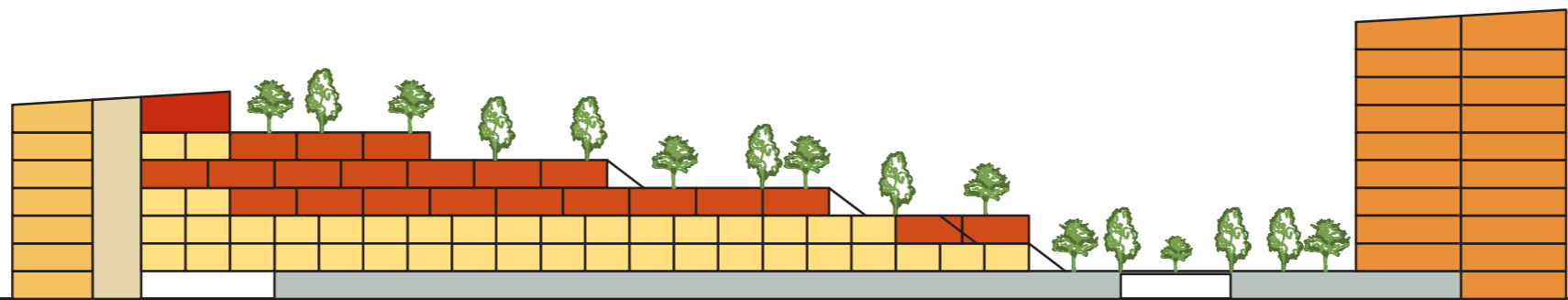

10 lagen



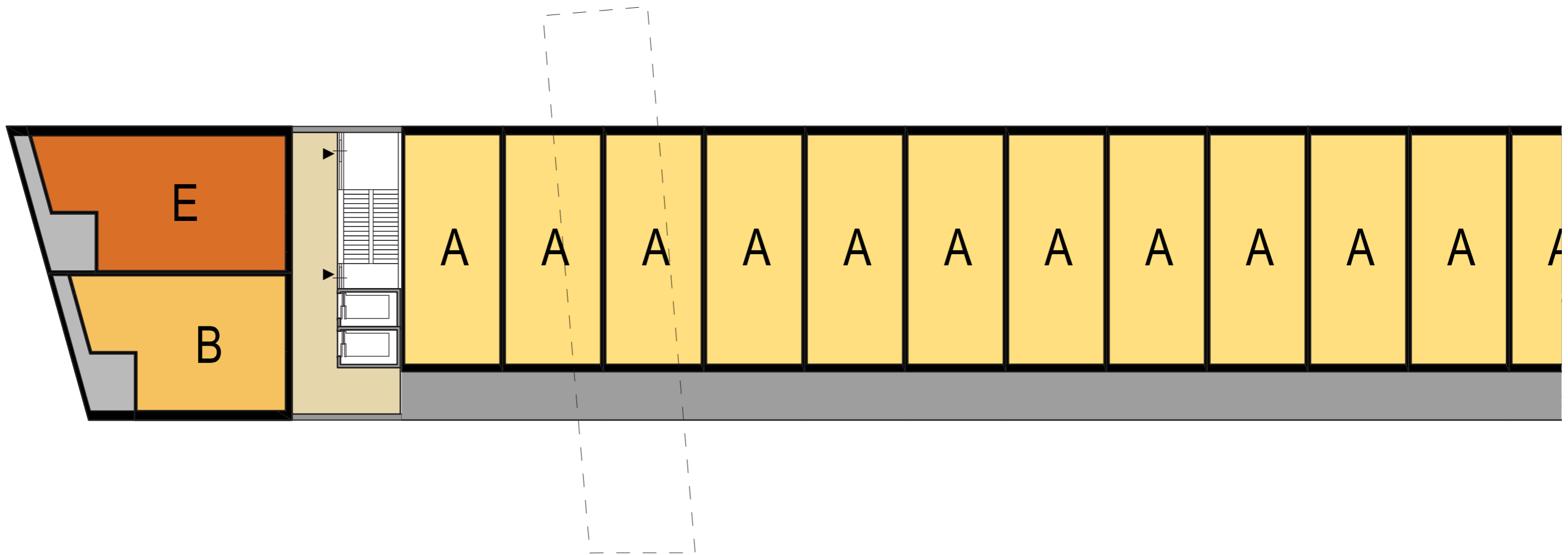
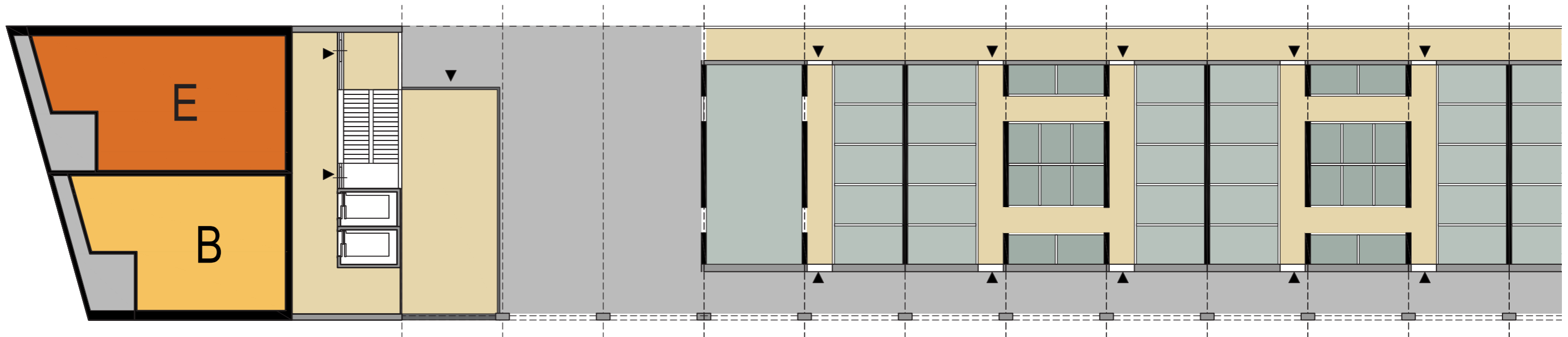

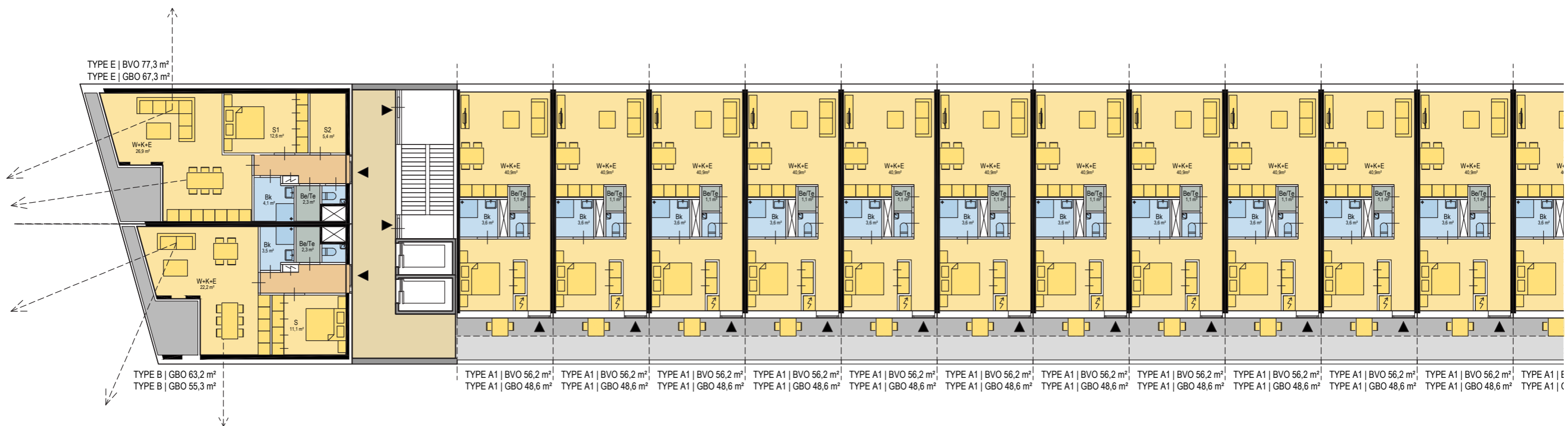

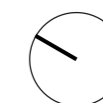
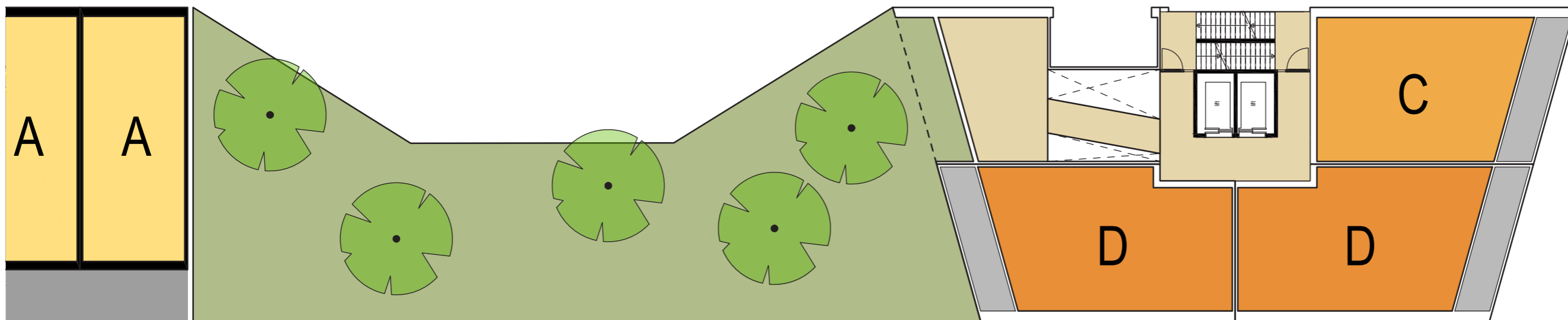
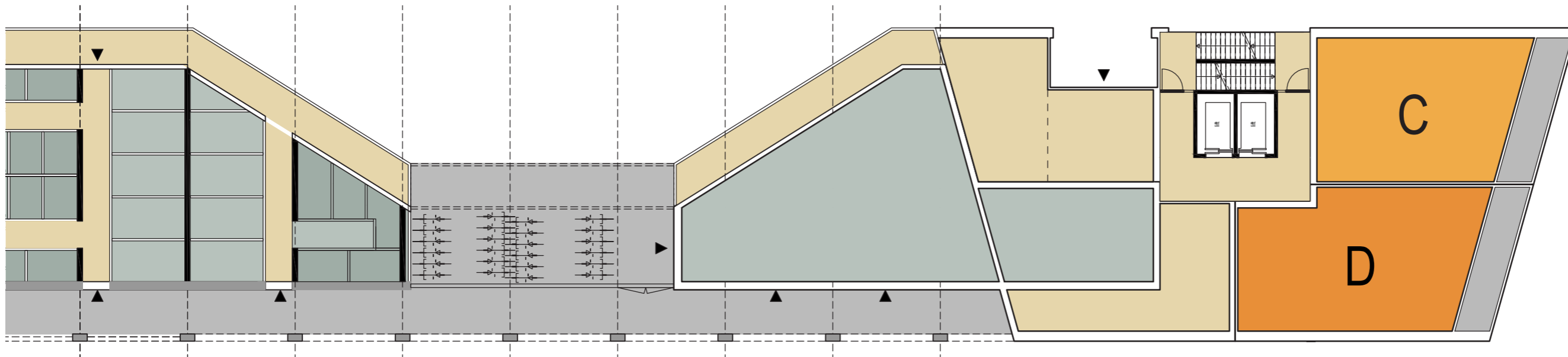

31227

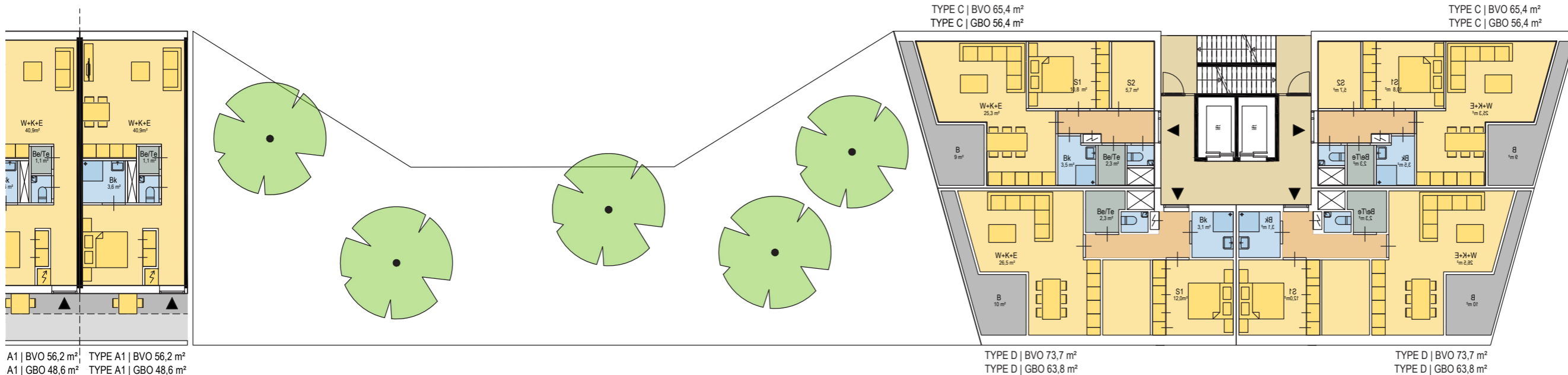

A1 | BVO 56,2 m<sup>2</sup> | TYPE A1 | BVO 56,2 m<sup>2</sup>  
A1 | GBO 48,6 m<sup>2</sup> | TYPE A1 | GBO 48,6 m<sup>2</sup>

TYPE C | BVO 65,4 m<sup>2</sup>  
TYPE C | GBO 56,4 m<sup>2</sup>

TYPE C | BVO 65,4 m<sup>2</sup>  
TYPE C | GBO 56,4 m<sup>2</sup>

TYPE D | BVO 73,7 m<sup>2</sup>  
TYPE D | GBO 63,8 m<sup>2</sup>

TYPE D | BVO 73,7 m<sup>2</sup>  
TYPE D | GBO 63,8 m<sup>2</sup>

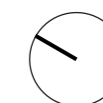



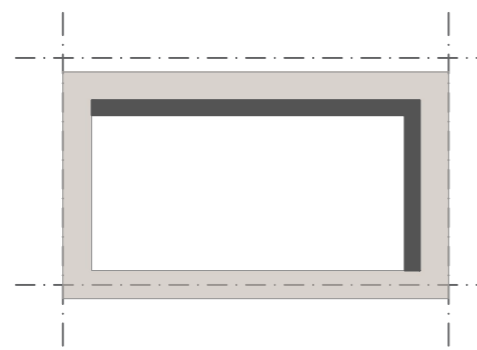
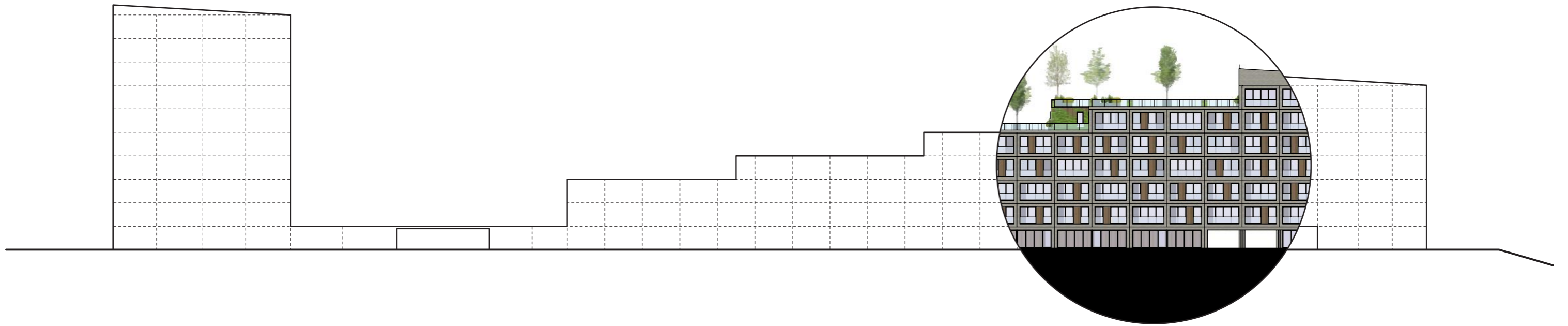
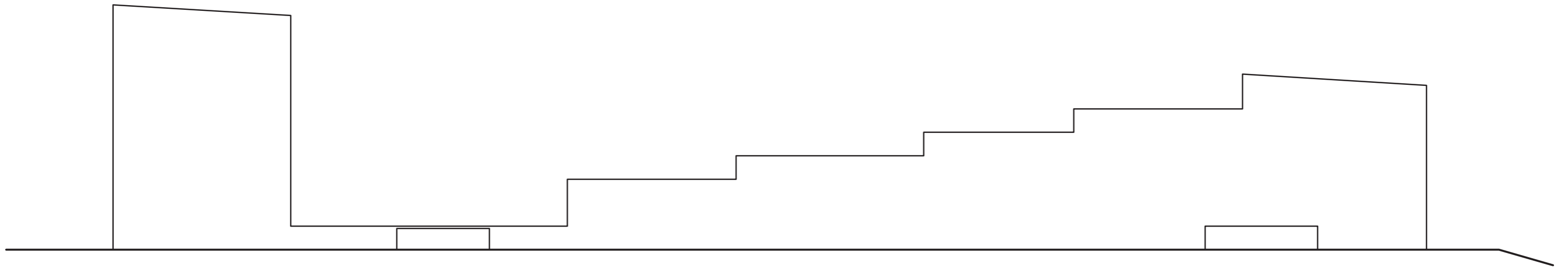

Prefab element per beuk

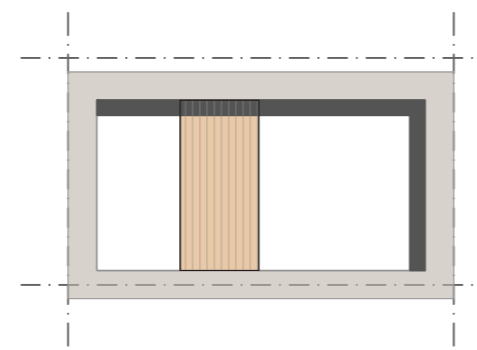

asymmetrische dichte invulling

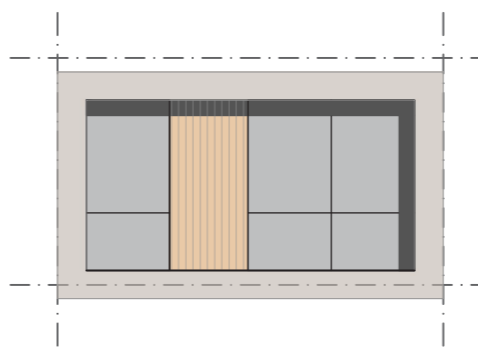

Kozijnen invulling

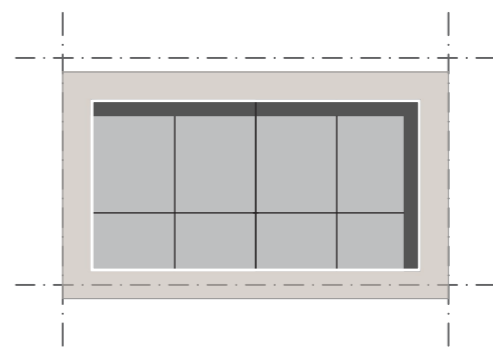

Accent met wit zetwerk kader

## OPBOUW GEVEL

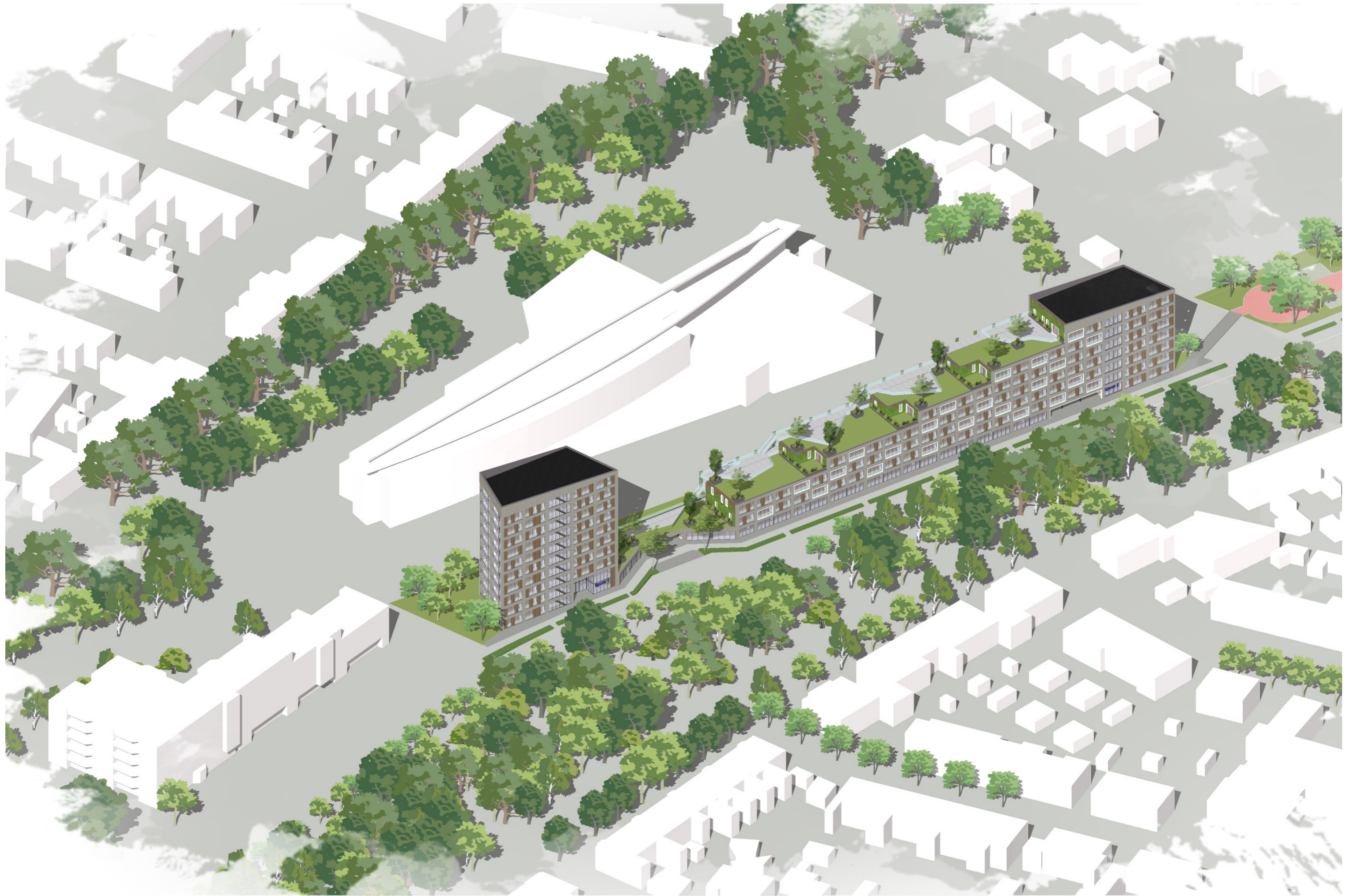















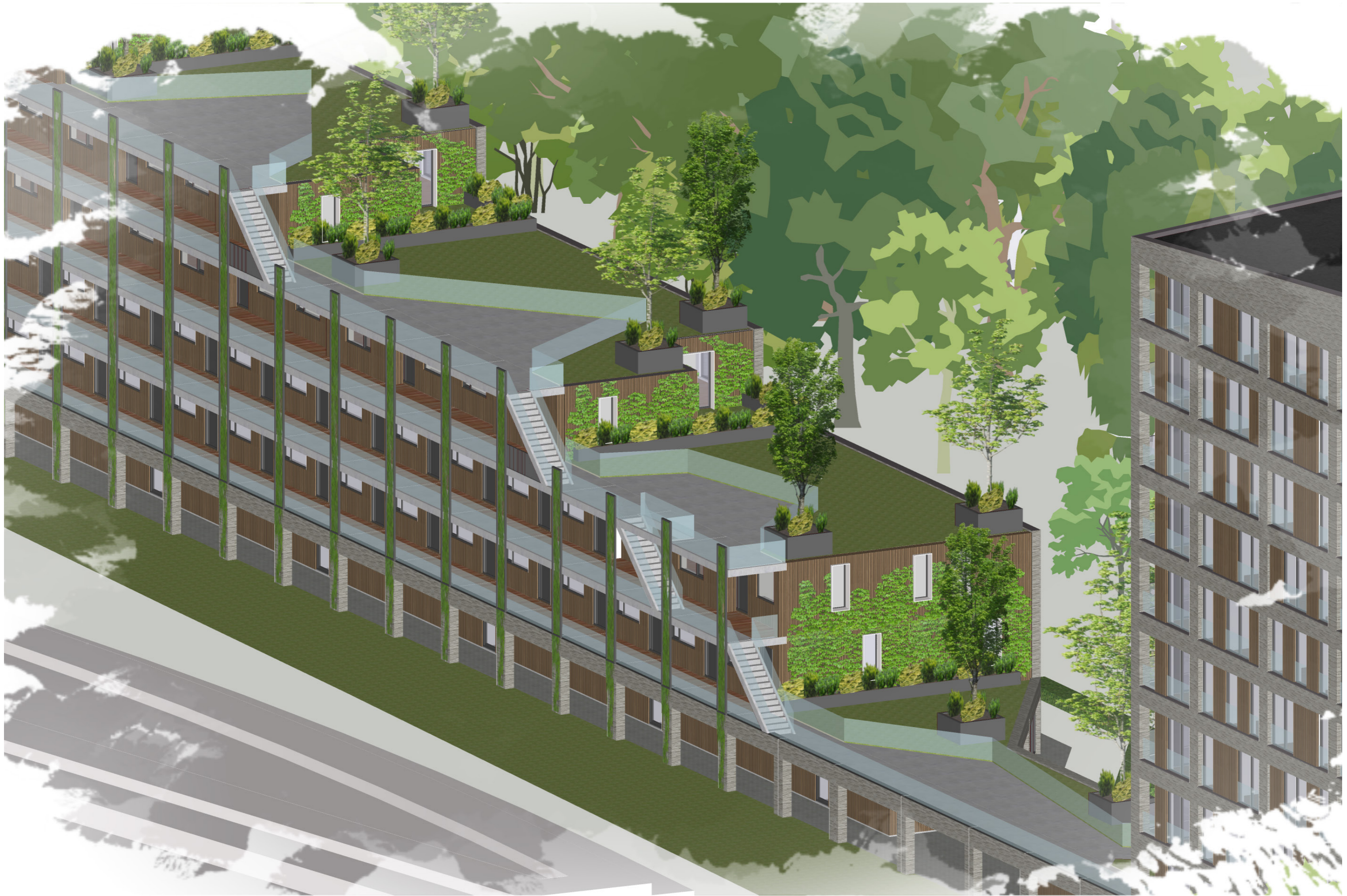





Spoor 1













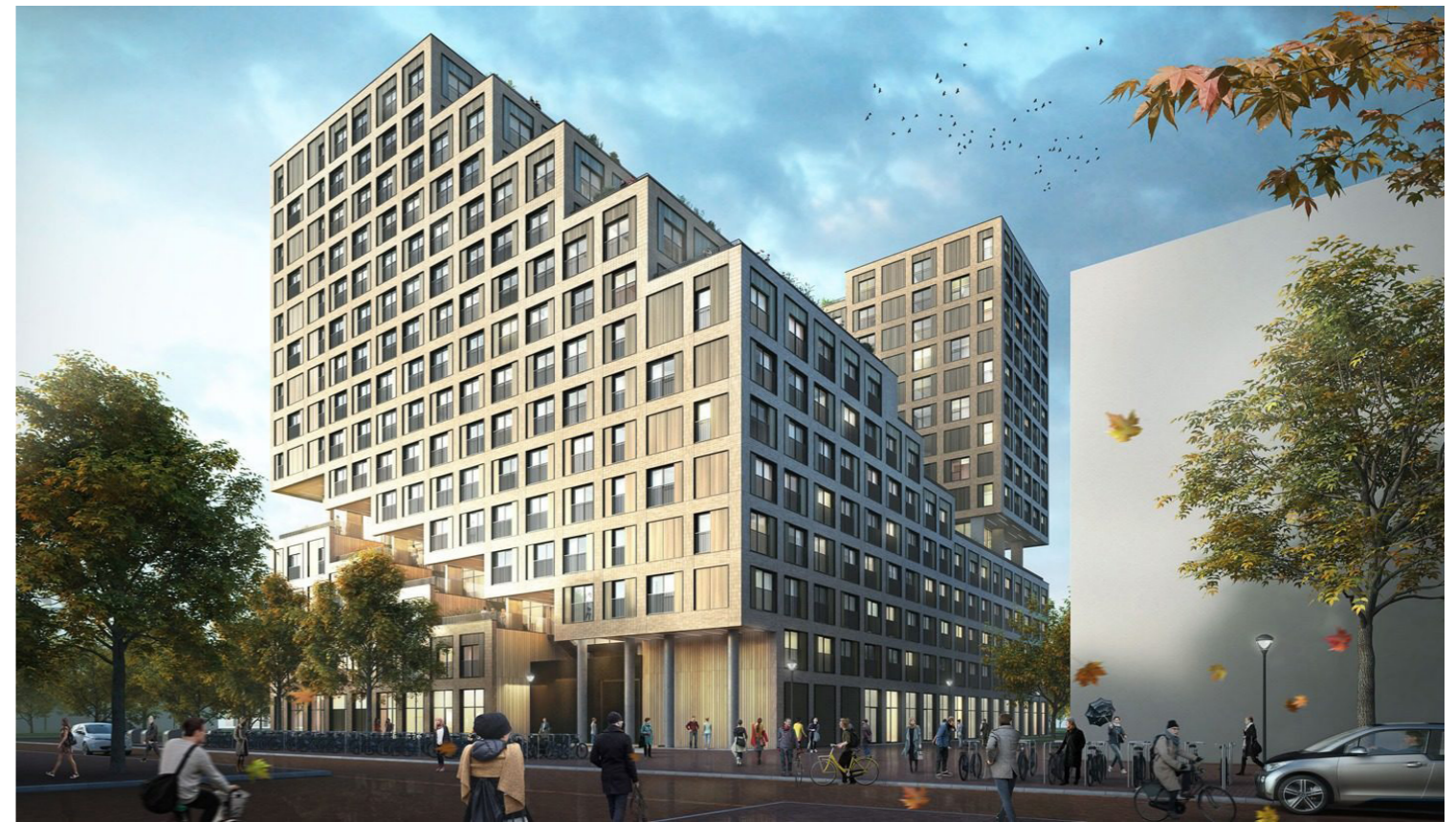
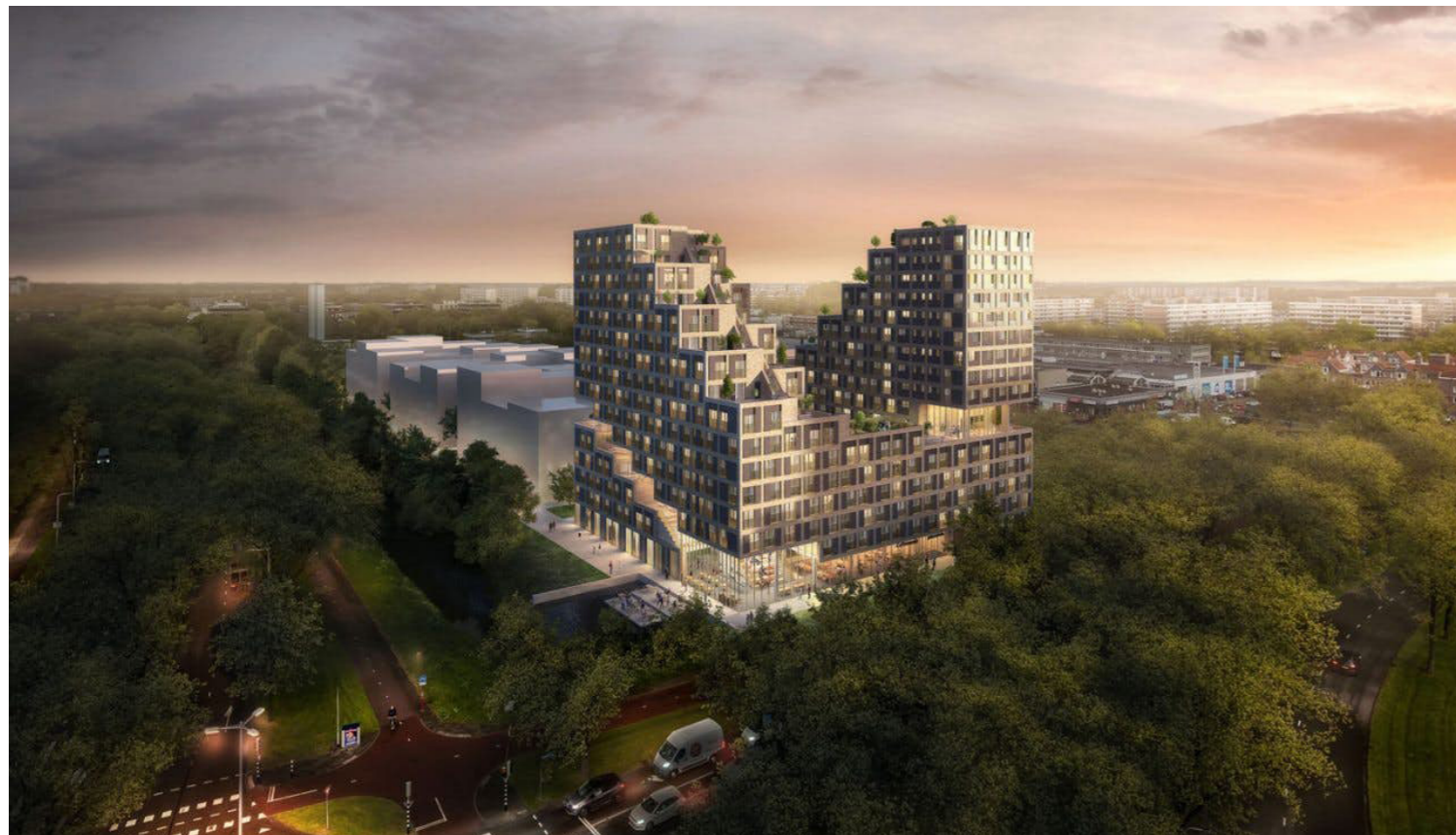

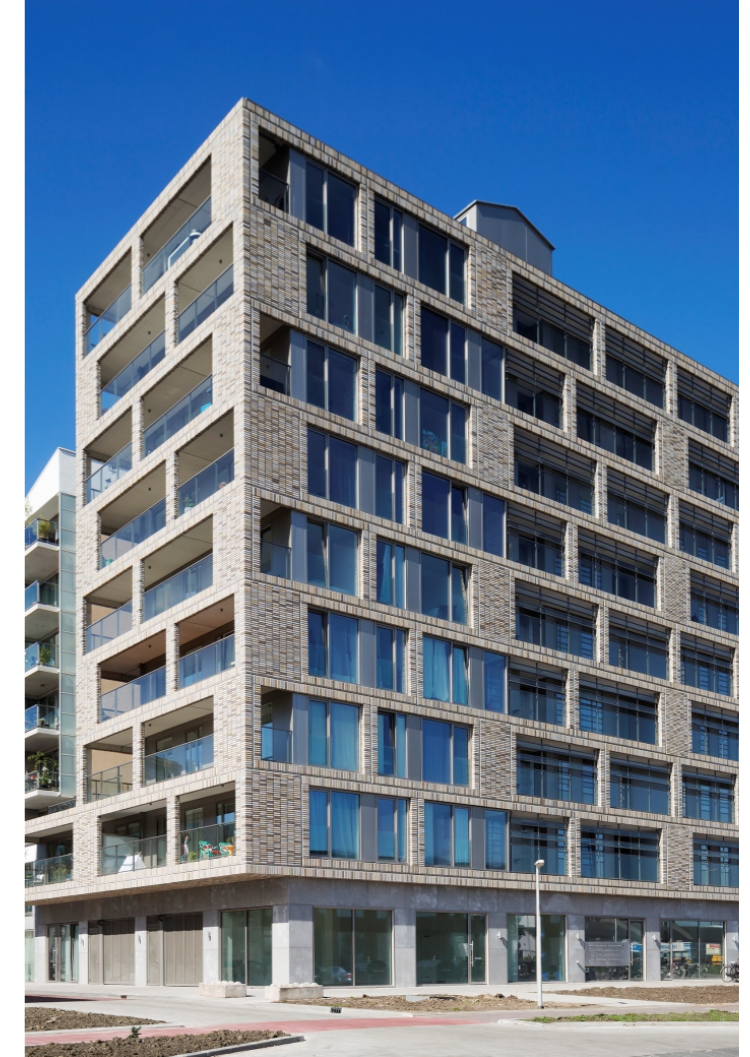
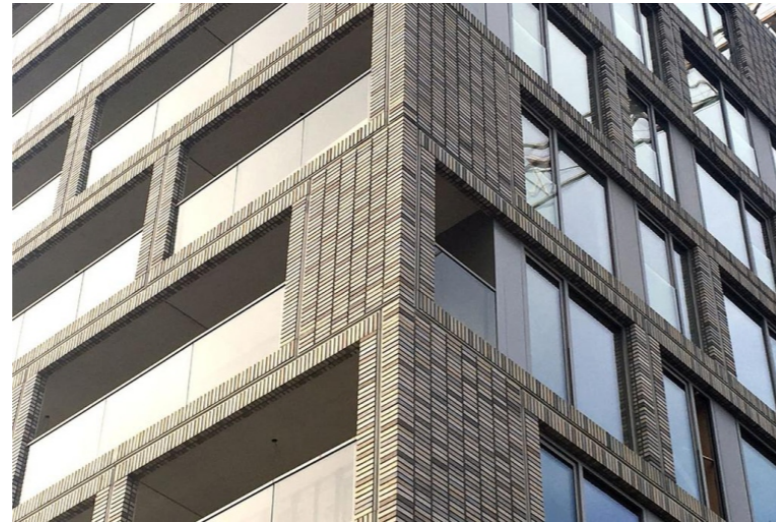

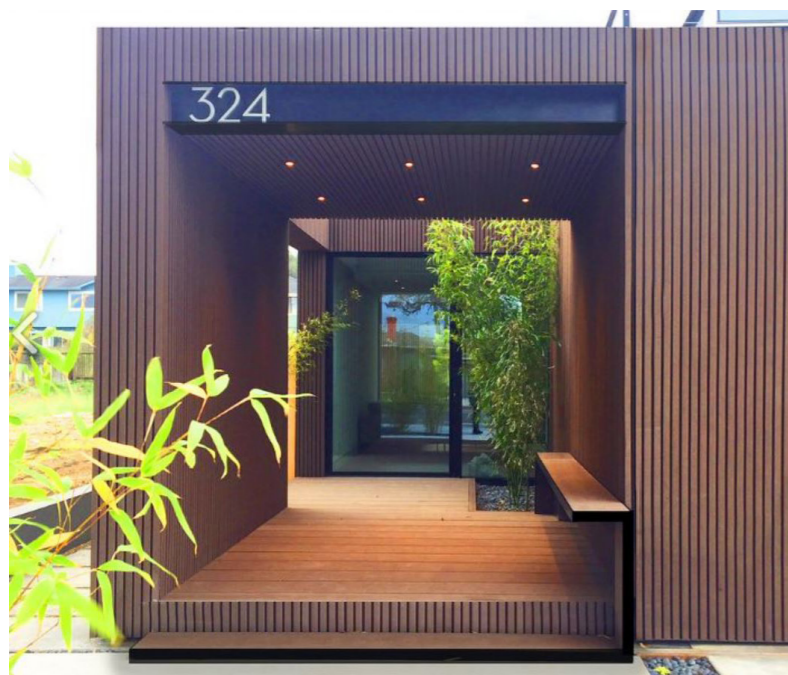
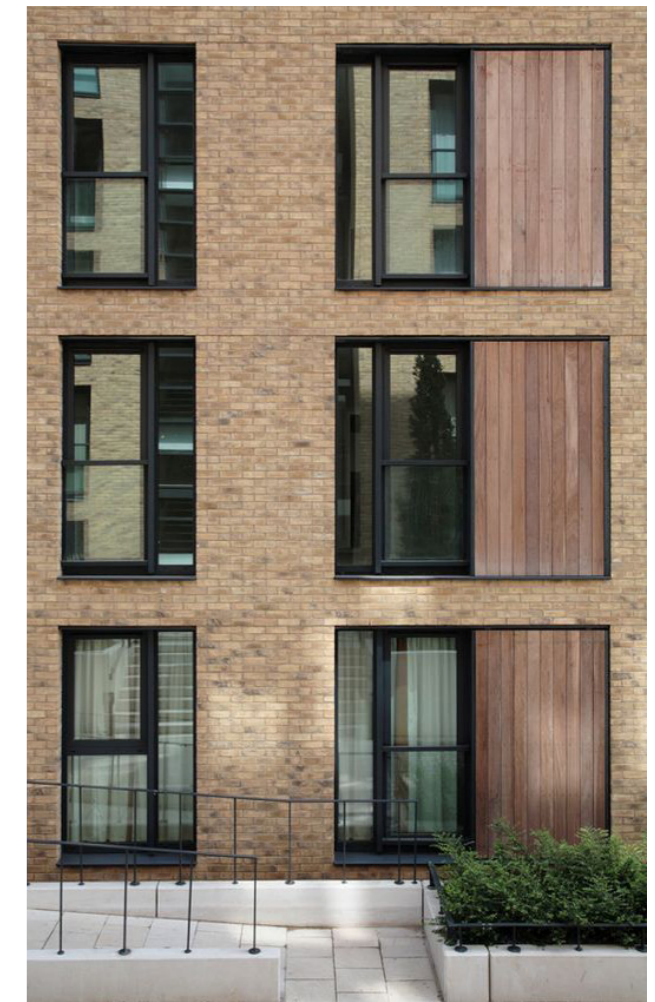

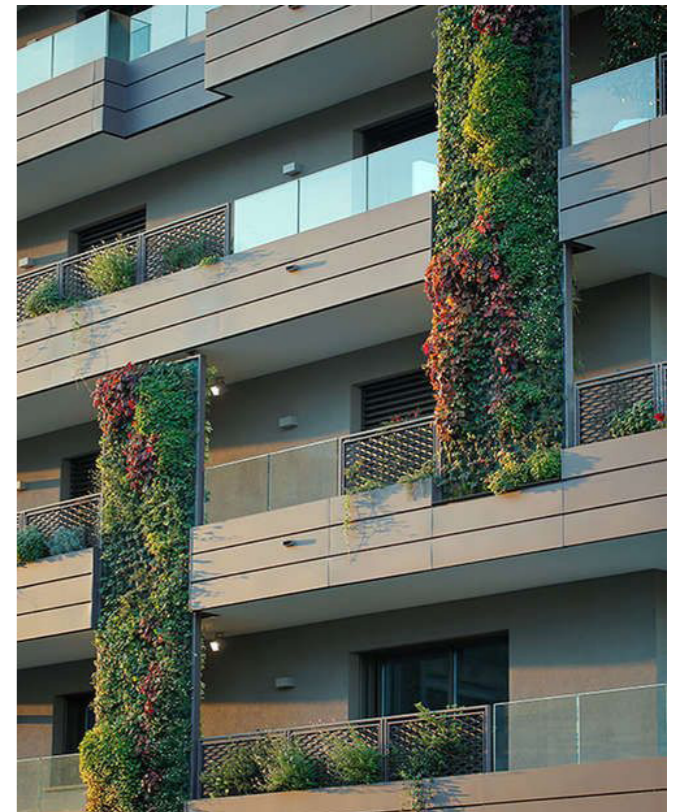
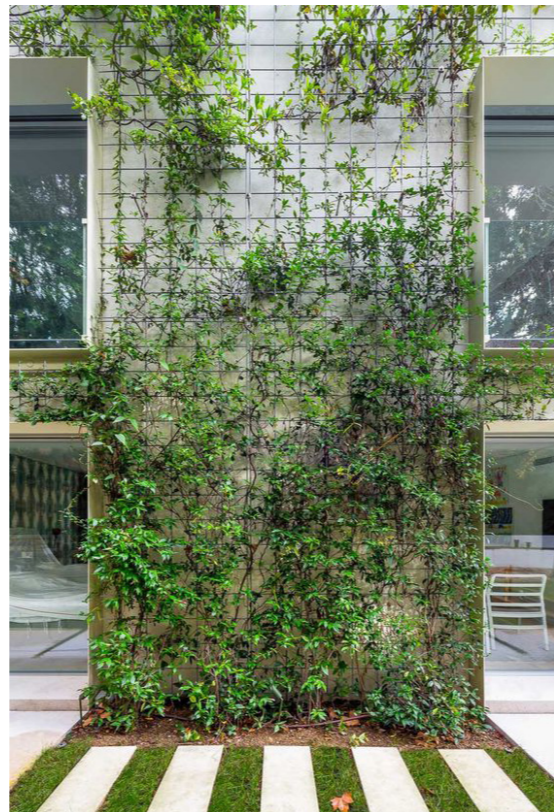



Spoor 1